



FG Elastomer bellows seal



Characteristics FG1

- Single seal - Rubber bellows
- Unbalanced
- Direction of rotation independent
- Pressure to Vacuum / 12 bar
- Temperature -30/+200°C
- Speed 10m/s max

The dimension L (working length) is in keeping with the working position (spring down)

Description	Materials
1 Collar ring	Stainless steel
2 Spring	Stainless steel
3 Retainer ring	Stainless steel
4 Bellows	Rubber
5 Slip ring	Carbon -Sic
6 Counterface	Alumina-Sic
7 Gasket	Rubber

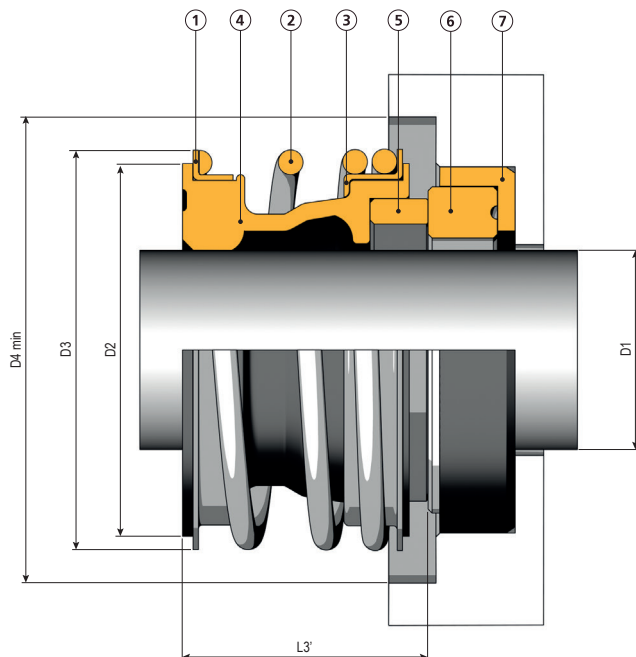

FG2

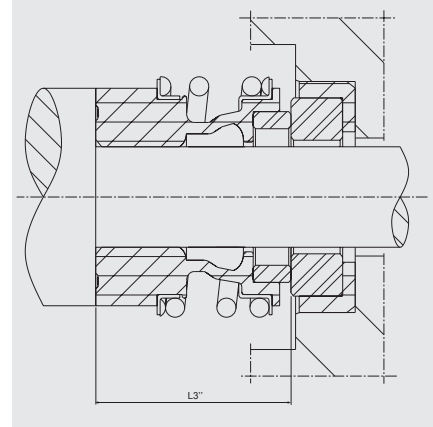

FG3

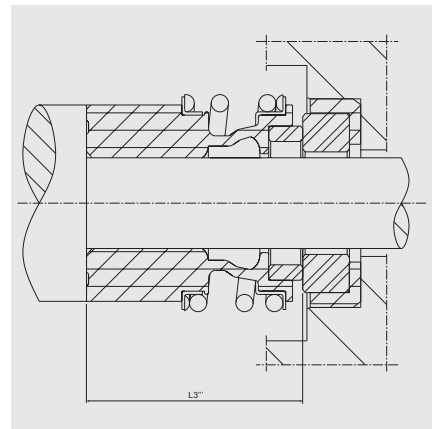

Stationary seats

type 1

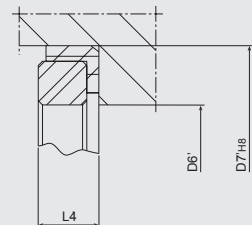

type 2

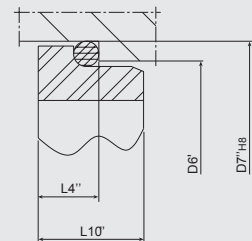

type 3

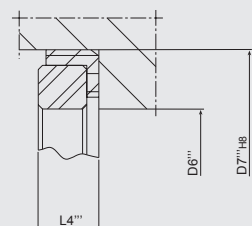



FG1-2-3

D1	FG 1-2-3						Type1			Type2				Type3		
	D2	D3	D4	L3'	L3''	L3'''	D6'max	D7'	L4'	D6''max	D7''	L4''	L10''	D6'''max	D7'''	L4'''
10	22,5	22,5	24	14,5	25,9	33,4	14	21	6,6	17	21	6,6	9	-	-	-
12	22,5	22	26	8,3	-	-	16	23	6,6	19	23	6,6	9	18	24	3,7
12	22,5	25,5	26	15	25,9	33,4	16	23	6,6	19	23	6,6	9	18	24	3,7
14	26,5	28,5	30	17	28,4	33,4	18	25	6,6	21	25	6,6	9	22	29,5	8
15	26,5	28,5	30	17	28,4	33,4	18	25	6,6	21	25	6,6	9	22	29,5	8
16	26,5	28,5	30	17	28,4	33,4	20	27	6,6	23	27	6,6	9	22	29,5	8
17	29	32	33	19,5	-	-	26	33	7,5	27	33	7,5	10	-	-	-
18	29	32	33	19,5	30	37,5	26	33	7,5	27	33	7,5	10	-	-	-
19	33	36	38	21,5	-	-	28	35	7,5	29	35	7,5	10	-	-	-
20	33	36	38	21,5	30	37,5	28	35	7,5	29	35	7,5	10	32	42	8
22	33	36	38	21,5	30	37,5	28	37	7,5	31	37	7,5	10,5	36	45	10
24	38	41	44	22,5	32,5	42,5	32	39	7,5	33	39	7,5	10,5	36	45	10
25	38	41	44	23	32,5	42,5	32	40	7,5	34	40	7,5	10,5	36	45	10
28	44	49	50	26,5	35	42,5	35	43	7,5	37	43	7,5	10,5	-	-	-
30	44	49	50	26,5	35	42,5	35	45	7,5	39	45	7,5	10,5	49	57	10
32	46	53,5	55	27,5	35	47,5	41	48	7,5	42	48	7,5	10,5	-	-	-
33	46	53,5	55	27,5	35	47,5	41	48	7,5	42	48	7,5	10,5	-	-	-
35	50	57	59	28,5	35	47,5	43	50	7,5	44	50	7,5	10,5	-	-	-
38	53	59	61	30	36	46	49	56	9	49	56	9	11,5	-	-	-
40	55	62	64	30	36	46	50	58	9	51	58	9	11,5	-	-	-
43*	58	65,5	67	30	36	51	54	61	9	54	61	9	11,5	-	-	-
45	60	68	70	30	36	51	56	63	9	56	63	9	11,5	-	-	-
48*	63	70,5	74	30,5	36	51	59	66	9	59	66	9	11,5	-	-	-
50	65	74	77	30,5	38	50,5	62	70	9,5	62	70	9,5	11,5	-	-	-
53*	70	78,5	81	33	36,5	59	65	73	11	65	73	11	14	-	-	-
55	72	81	83	35	36,5	59	67	75	11	67	75	11	14	-	-	-
58*	75	85,5	88	37	41,5	59	70	78	11	70	78	11	14	-	-	-
60	79	88,5	91	38	41,5	59	72	80	11	72	80	11	14	-	-	-
65	84	93,5	96	40	41,5	69	77	85	11	77	85	11	14	-	-	-
68*	88	96,5	100	40	41,2	68,7	81	90	11,3	81	90	11,3	14	-	-	-
70	90	99,5	103	40	48,7	68,7	84	92	11,3	83	92	11,3	14	-	-	-
75	105	105	109	40	-	-	-	-	-	88	97	11,3	14	-	-	-
80	94	110	115	40	-	-	96	105	12	-	-	-	-	-	-	-

NB:

In these cases of the FG series are in accordance with DIN 24960/EN 12756:

FG1 seat of the counterface

FG2 seat of the counterface + axial length (L1K)

FG3 seat of the counterface + axial length (L1N)

The radial dimension (d3) of the rotating part of all three types are not respected to the rules of DIN

*Production on order



Seal axial clearance (l3) tolerances

$D1 \leq 12$	$\pm 0,5$
$14 \leq D1 \leq 18$	± 1
$20 \leq D1 \leq 25$	$\pm 1,5$
$28 \leq D1 \leq 70$	± 2

FG in inches

D1	D1 inches	D2	D3	D4	L3	D7	L4
9,52*	3/8"	22	22,8	30	16,6	25,4	8
11,11*	7/16"	22	22,8	30	16,6	25,4	8
12,7*	1/2"	22	22,8	30	16,6	25,4	8
14,29	9/16"	26,5	28	30	17	31,75	10,3
15,87	5/8"	26,5	28	30	17	31,75	10,3
17,46*	11/16"	33	36	38	19,6	34,925	10,3
19,05*	3/4"	33	36	38	19,6	34,925	10,3
25,4	1"	38	41	54	20,63	41,26	11,1